











EL400

Preferred for Precision Measurements



-  Machine specific versions for Milling, Turning and EDM applications
-  Optical Glass or Magnetic encoders **RATED TO IP67**
-  4-axes versions* with internal summing for Knee and Quill Mill axes
-  Probe interface included as standard
-  Programmable machine default settings
-  Latest SDM manufactured design
-  Segmented and Linear compensation
-  Clear wide-viewing angle display
-  Quality International manufacturer
-  Ideal replacement for retrofit. Multiple Encoder interface options available.
-  Manufactured to ISO 9001:2000



Milling Machines

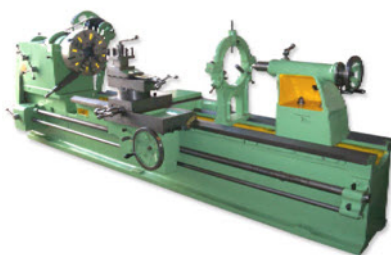

Turning Machines



Manual EDM Machines

* 4-axes encoder input with 3-axes display



EL400

Digital Readout Series

Feature	Mill	Lathe	Simple	EDM
No. Axes	2, 3, 4	2, 3	1, 2, 3	2
Display	LED			
Case	Die-cast Aluminium			
Power	90...265 VAC (50/60 Hz)			
Storage Temperature	-20°C to +70°C			
Operating Temperature	0°C to +50°C			
Relative Humidity	20% to 85% Non-condensing			
Dimensions (H x W x D)	155mm x 270mm x 80mm			
USB Service	Fitted as standard			
Auxiliary Port (6-outputs + RS232)				

Feature	Mill	Lathe	Simple	EDM
Half Function				
Axis home reference				
Machine Reference				
One touch axis zero				
Sub Datums				
Tool Offsets				
Bolt-hole circle (PCD)				
Arc Bolt Hole				
Arc Contouring				
Grid Hole function				
Taper calculator				
Internal axis summing				
Vectoring function				
Line Hole function				
Calculator (Trigonometric)				
Pre-set Depth				
Encoder fail detection				
Memory backup				

Standard
 Option

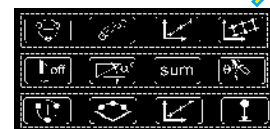
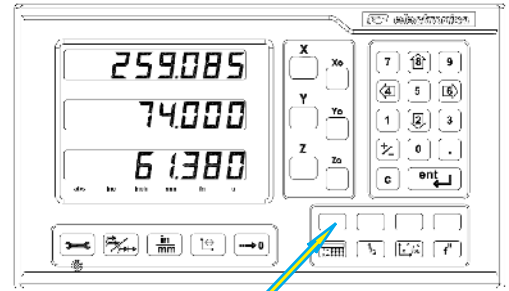
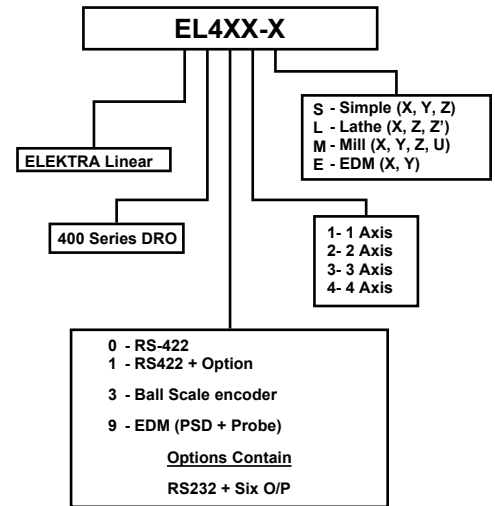

Mill Functions
 Lathe Functions
 EDM Functions



Electronica Mechatronic Systems (I) Pvt. Limited
 Unit No 37 & 44
 Electronic Co-op Estate
 Pune-Satara Road
 Pune 411 009
 India
 Tel: +91 20 2422 4440
 Fax: +91 20 2422 1881
 e-mail: export@electronicaems.com
 web: electronicaems.com

Dealer Stamp

