



High Performance Oil Skimmer



KTS

New conceptual Oil Skimmer, CNC-OS

for efficient management of coolant

Much faster and efficient operating by speed control
 Can be used on multiple machines (Movable Stand type)



Specifications

Speed Control	-	PWM
Power source	Voltage	Input : AC 100~240V Output : DC 3 ~ 19V
	Herz	50/60Hz
Dimension (L x W x H)	mm	110 x 150 x 350(~Max.480)
Weight	kgf	2.6





Horizontal impeller inducing vortex

Providing an excellent performance inducing vortex to pull and collect oil by impeller

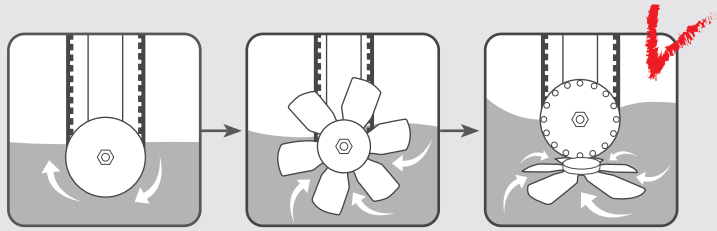

Speed Control operating efficiently

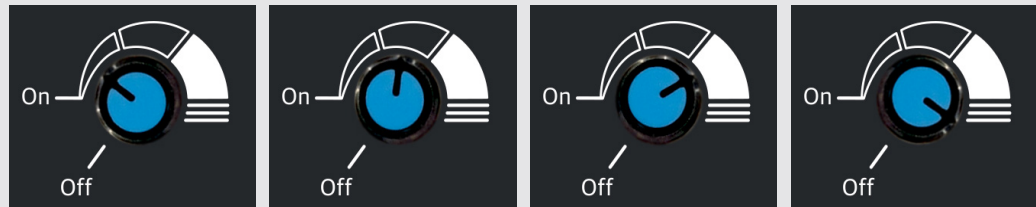

a little lubricant in tank ◀ **Recommended** ▶ lots of lubricant in tank



PEO Coating

Improving anti-corrosion

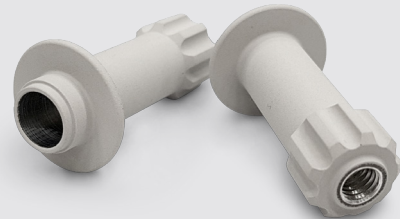

PEO coating on Top pulley

* PEO (Plasma Electrolytic Oxidation)

Electrochemical Surface Treatment in which surface oxidation is occurred with micro-arcs in aqueous electrolytic solution under electric potential. (KTS own technique)



* Salt Spray Endurance Test

Product Dimensions

(Unit : mm)

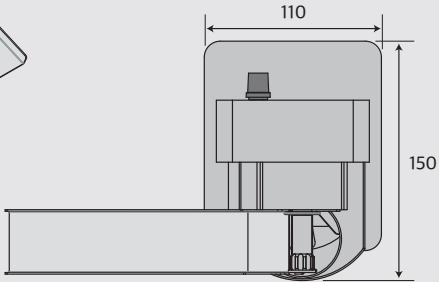
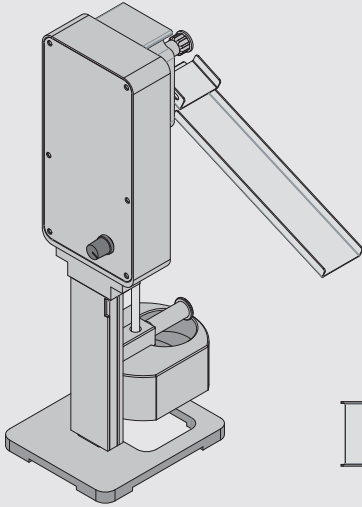

Top view

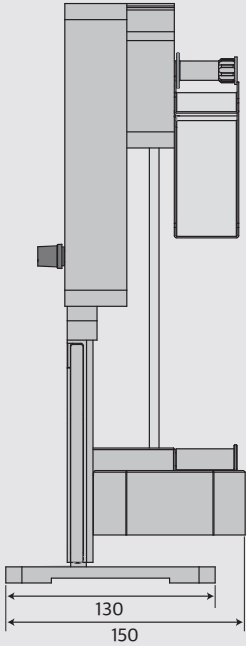

Left side view

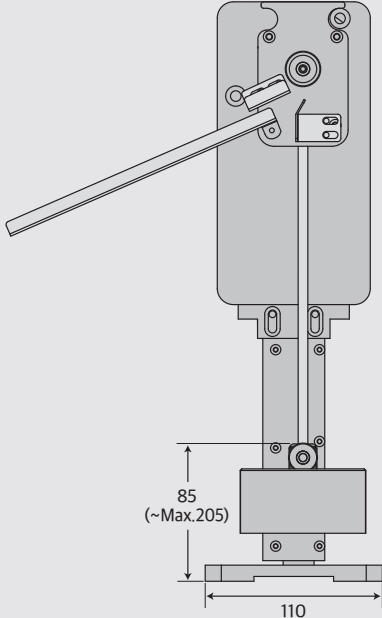

Front view

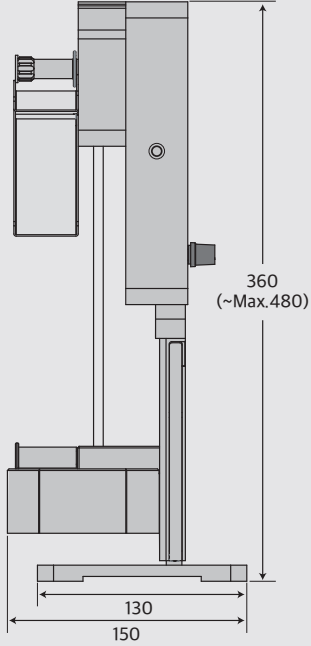

Right side view



Korea Technology Solutions

www.cnc-all.com

Tel. : +82-31-233-7773 | Fax. : +82-504-194-1511 | E-mail : kts@ktsolutions.co.kr